

SERIES F18

Dynapar™ brand

For Stepper & Small Servo Motors

Key Features

- Under 2.0" Diameter Package with High 10,000PPR Capability
- Easy to Install Hollowshaft and Spring Tether Design
- Up to 120°C Temperature Range Doesn't Limit Motor Performance



SPECIFICATIONS

STANDARD OPERATING CHARACTERISTICS

Code: Incremental with commutation option, Optical

Resolution: 500, 512, 1000, 1024, 2000, 2048, 2500, 4096, 5000, 8192, 10,000 PPR incremental with 4, 6, 8 or 12 pole commutation channels

Accuracy: Incremental: ± 2.5 arc-mins. max. edge to any edge; Commutation: ± 6 arc-mins. max.

Phasing for CCW rotation of motor shaft (viewing encoder cover): A leads B by 90° and U leads V leads W by 120° .

Minimum edge separation A to B is 45° .

Index to U channel: $\pm 1^\circ$ mech. index pulse center to U channel edge.

Index Pulse Width: 90° gated A and B high; (180° gated B high gating options available - consult factory)

ELECTRICAL

Input Power Requirements: $5 \pm 10\%$ VDC at 150 mA max (incremental only); 175 mA max. (incremental and commutation), excluding output load

Output Signals:

Line Driver: sink / source 40 mA max.,
Open Collector Incremental (≤ 2048 PPR): 16 mA sink max.
Open Collector Commutation: 30 mA sink max. (2.0 k Ω pull-ups in encoder)

Frequency Response:

PPR ≤ 2048 : 250 kHz; PPR > 2048 : 500 kHz

Termination: 16 pin, fully shielded, 2mm pitch, double row header. Accessory mating cable assembly available: 26 AWG twisted pair, jacketed and shielded with copper drain wire

MECHANICAL

Weight: 4 oz. (110 gm) typ.

Dimensions: Outside Diameter with cover: 1.96" (49.8mm), without cover 1.85" (47.0mm); Outside collar height 1.71" (43.4mm), inside collar height 1.50" (38.1mm)

Material: Bearing housing: aluminum;
Cover: high temperature, glass filled polymer;

Hub: Brass; Disk: 0.030" thick glass

Finish: Cover: RAL 7010 (dark grey)

Moment of Inertia: 5.3×10^{-4} in-oz sec.² (37.3 gm-cm²)

Hub Diameters: 1/4", 3/8", 7/16", 1/2", 6mm, 8mm, 10mm, 12mm standard

Bore Dia. Tolerance: $+0.001/-0.000$ " ($+0.025$ mm/ -0.000 mm)

Mating Shaft Length: 1.62" (41 mm) minimum for outside shaft collar. 0.50 inch minimum for inside shaft collar

Mating Shaft Runout: 0.002" (0.05 mm) max. (Includes shaft perpendicularity to mounting surface)

Mating Shaft Axial movement: ± 0.060 " (± 1.52 mm)

Mounting: Four standard configurations are available for tethers. A choice of U.S. and Metric screws are included. Mounting holes should be 0.01" (0.254 mm) true position to shaft for best encoder operation.

Shaft clamp: 2 #6-32 set screws in collar around hub shaft (will not mar shaft)

Electrical/Mechanical Alignment Range: $\pm 15^\circ$ mechanical typical (see tether options)

Acceleration: 100,000 rad/sec.² max.

Max. Velocity: RPM = (Frequency / PPR) x 60; or 12,000 RPM, whichever is less;

Bearing Life: $[(3.6 \times 10^9) / \text{RPM}]$ Hours; e.g. 605,000 hours @ 6,000 RPM

(Based on bearing manufacturer's suggested calculation for 6803ZZ with 37N equivalent dynamic load - including preload and tether reaction loads - at 6000 RPM continuous with adequate lubrication)

ENVIRONMENTAL

Operating Temperature: 0° to $+120^\circ\text{C}$

Storage Temperature: -40° to $+120^\circ\text{C}$

Shock: 100 Gs for 6 msec duration

Vibration: 2.5 Gs at 5 to 2000 Hz

Relative Humidity: 90% non-condensing

Enclosure Rating: NEMA 1 / IP40 (for models with cover)



SERIES F18

Dimensions

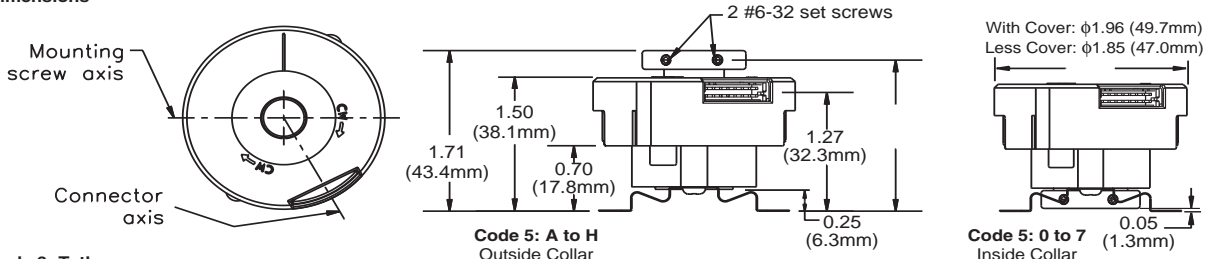

Code 3: Tethers

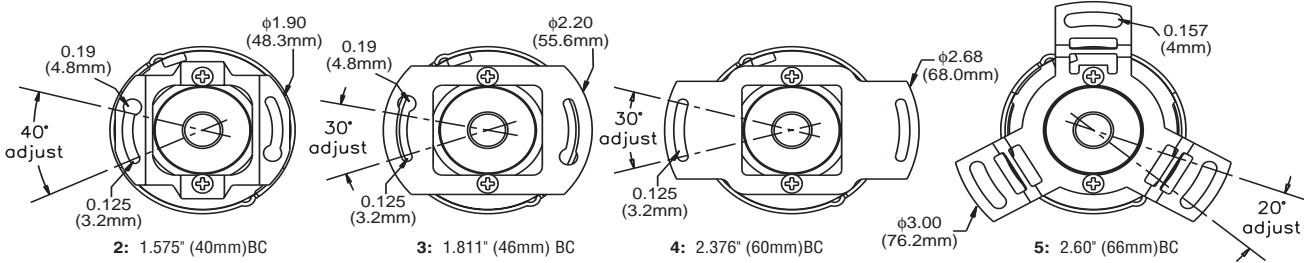

Electrical Connections

Pin	Function*	Cable Wire Color
1	VCC	RED
2	U	Brown
3	GND	BLACK
4	V	GRAY
5	A	BLUE
6	W	WHITE
7	A	BLUE/BLACK
8	NONE	NONE
9	B	GREEN
10	U	BROWN/BLACK
11	B	GREEN/BLACK
12	V	GRAY/BLACK
13	Z	VIOLET
14	W	WHITE/BLACK
15	Z	VIOLET/BLACK
16	NONE	NONE

* Function availability dependant on Model

Mating Cable Assembly:

Incremental only, 111752-000x
 Incremental + Comm., 111753-000x
 x= length in feet

Output Waveforms

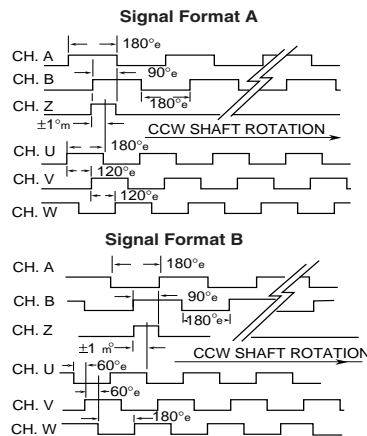

Code 6: Termination

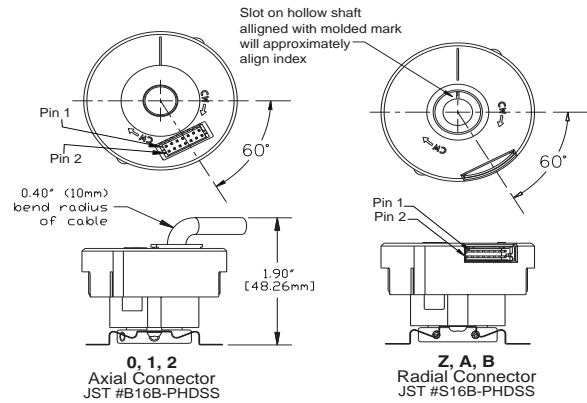

Ordering Information

To order, complete the model number with code numbers from the table below:

Code 1: Model	Code 2: PPR, Poles	Code 3: Tether	Code 4: Electrical	Code 5: Shaft/Bore	Code 6: Termination
F18	<input type="checkbox"/> <input type="checkbox"/> <input type="checkbox"/> <input type="checkbox"/> <input type="checkbox"/>	<input type="checkbox"/>	<input type="checkbox"/>	<input type="checkbox"/>	<input type="checkbox"/>

Ordering Information																																																						
F18	Size 18 Commutating Encoder	Incremental channels only	0 No Tether 2 2 #2 on 1.575" Diameter 3 2 #4 on 1.811" Diameter 4 2 #4 on 2.376" Diameter 5 3 #4 on 2.60" Diameter 7 2 M2.5 on 40 mm Diameter 8 2 M3 on 46 mm Diameter 9 2 M3 on 60 mm Diameter A 3 M3 on 66 mm Diameter	Available when Code 2 is ≤ 2048/0 0 5V in, open collector out incremental only C 5V in, open collector out incremental only - reverse phase Available when Code 2 is XXXX/0 3 5V in, line driver out incremental only D 5V in, line driver out incremental only - reverse phase Available when Code 2 is XXXX/4, XXXX/6, XXXX/8 or XXXX/C 6 5V in, line driver out for incremental; 5V in, open collector out for commutation E 5V in, line driver out for incremental; 5V in, open collector out for commutation - reverse phase 9 5V in, line driver out for incremental; 5V in, line driver out for commutation F 5V in, line driver out for incremental; 5V in, line driver out for commutation - reverse phase	Inside Collar: 0 1/4 in. 1 3/8 in. 2 7/16 in. 3 1/2 in. 4 6 mm 5 8 mm 6 10 mm 7 12 mm Outside Collar: A 1/4 in. B 3/8 in. C 7/16 in. D 1/2 in. E 6 mm F 8 mm G 10 mm H 12 mm	<table border="1"> <thead> <tr> <th colspan="4">Code</th> </tr> <tr> <th>Connector/Cable</th> <th>Wire</th> <th>Length</th> <th></th> </tr> <tr> <th>Axial</th> <th>Radial</th> <th>Pigtail</th> <th></th> </tr> </thead> <tbody> <tr><td>0</td><td>Z</td><td>N/A</td><td>None</td></tr> <tr><td>1</td><td>A</td><td>J</td><td>1 Ft.</td></tr> <tr><td>2</td><td>B</td><td>K</td><td>2 Ft.</td></tr> <tr><td>3</td><td>C</td><td>L</td><td>3 Ft.</td></tr> <tr><td>4</td><td>D</td><td>M</td><td>4 Ft.</td></tr> <tr><td>5</td><td>E</td><td>N</td><td>5 Ft.</td></tr> <tr><td>6</td><td>F</td><td>P</td><td>6 Ft.</td></tr> <tr><td>7</td><td>G</td><td>Q</td><td>7 Ft.</td></tr> <tr><td>8</td><td>H</td><td>R</td><td>8 Ft.</td></tr> </tbody> </table>	Code				Connector/Cable	Wire	Length		Axial	Radial	Pigtail		0	Z	N/A	None	1	A	J	1 Ft.	2	B	K	2 Ft.	3	C	L	3 Ft.	4	D	M	4 Ft.	5	E	N	5 Ft.	6	F	P	6 Ft.	7	G	Q	7 Ft.	8	H	R	8 Ft.
		Code																																																				
Connector/Cable	Wire	Length																																																				
Axial	Radial	Pigtail																																																				
0	Z	N/A	None																																																			
1	A	J	1 Ft.																																																			
2	B	K	2 Ft.																																																			
3	C	L	3 Ft.																																																			
4	D	M	4 Ft.																																																			
5	E	N	5 Ft.																																																			
6	F	P	6 Ft.																																																			
7	G	Q	7 Ft.																																																			
8	H	R	8 Ft.																																																			
Incremental plus Commutation channels	0500/† 2500/† 0512/8 4096/† 1000/† 5000/† 1024/† 8192/† 2000/† 10E3/†* 2048/† 10E3/†* *= 10000/†	Examples: 1024/8 is 1024PPR, 8 pole; 2000/C is 2000PPR, 12 pole			<p>CONNECTION OPTIONS</p> <p>You may choose an integral connector mounted in axial or radial position. Available with or without mating connector/cable.</p> <p>Alternatively, a direct-solder pigtail cable is offered.</p>																																																	

† Available with 4, 6, 8 or 12 pole. (12 pole is designated by character "C")